

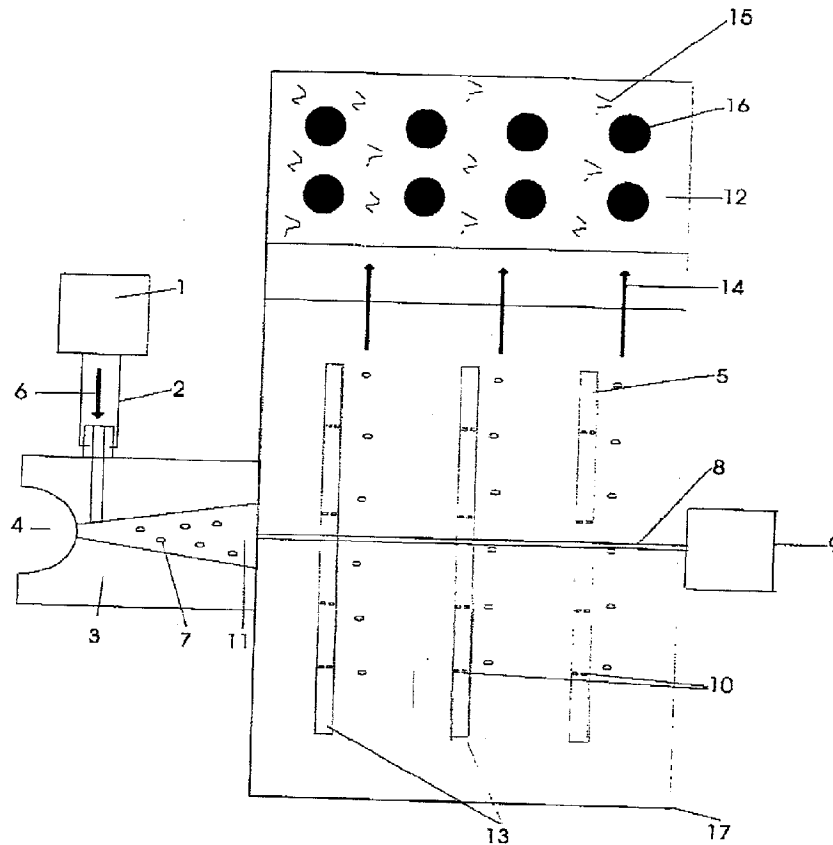

(72) CONRAD, Wayne Ernest, CA
(72) CONRAD, Helmut Gerhard, CA
(72) SZYLOWIEC, Ted, CA
(71) FANTOM TECHNOLOGIES INC., CA
(51) Int.Cl.⁶ B01J 3/00

(54) **METHODE ET APPAREIL POUR AUGMENTER LA
DISSOLUTION D'UN GAZ DANS UN LIQUIDE**
(54) **METHOD AND APPARATUS FOR ENHANCING THE
DISSOLUTION OF A GAS IN A LIQUID**



(57) A process for compressing a liquid and a gas comprises introducing at least one gas and at least one liquid into a prandtl layer pump and passing the gas and the liquid through the prandtl layer pump to obtain a liquid/gas mixture.

Title: METHOD AND APPARATUS FOR ENHANCING THE DISSOLUTION OF A GAS IN A LIQUID

5 **FIELD OF THE INVENTION**

This invention relates of a method for dissolving a gas into a liquid. The gas may be present either by itself or in combination with one or more other gasses and/or a liquid. Further, the liquid into which the gas is to be dissolved may be present by itself or may also have one or more liquids and/or one or more other gases associated therewith.

BACKGROUND OF THE INVENTION

15 In many applications, it is desirable to dissolve a gas into a liquid. Various different apparatus have been developed in the past for dissolving gases into liquids. Examples of such techniques include the use of a sparger, venturi or other inlet port to introduce a gas into a liquid and allow the gas to percolate upwards through the liquid. It has also been known to pass a liquid and a gas through a pump so as to intimately mix the liquid and the gas to obtain a gas liquid mixture.

20 One disadvantage of these techniques is that only a limited amount of the gas is dissolved or exposed to the liquid. Further, if a pump is used, only limited pressures may be exerted on the liquid/gas mixture in order to prevent cavitation. In order to obtain higher dissolution efficiencies, the process must be repeated. This may be achieved by recycling the undissolved gas and recycling it through the process.

30 **BRIEF SUMMARY OF THE INVENTION**

In accordance with the instant invention, there is provided a method for dissolving a gas into a liquid comprising introducing a stream of the gas which is to be dissolved in a liquid, together with the liquid, into a prandtl layer pump. The pump

- 2 -

compresses the liquid and the gas together so as to enhance the dissolution of the gas into the liquid. The increased pressure which can be applied to a liquid/gas mixture by means of the prandtl layer pump promotes the dissolution of the gas into the liquid.

5 In accordance with another embodiment, the resultant gas/liquid mixture is passed to an expansion zone (i.e. a decompression zone) wherein the pressure to which the liquid/gas mixture is exposed is rapidly reduced. The rapid depressurization allows at least some of the dissolved gas to come out of solution to
10 form a suspension of ultra-fine bubbles (e.g. 1-5 μ).

One advantage of the instant invention is that, by the use of a prandtl layer pump, high pressure may be applied to a liquid/gas mixture without risk of cavitation.

15 Another advantage of the instant invention is that intimate contact is obtained between the gas and the liquid thus promoting the dissolution of the gas into the liquid. Further, if the gas/liquid mixture is rapidly depressurized, then a mixture containing an ultra fine dispersion of gas bubbles in the liquid may be obtained.

20

BRIEF DESCRIPTION OF THE DRAWINGS

These and other advantages of the instant invention may be more fully and particularly understood in connection with the following description of a preferred embodiment of the
25 invention in which:

Figure 1 a schematic diagram of an apparatus according to the instant invention; and,

Figure 2 is an alternate embodiment of a schematic diagram of the apparatus of Figure 1.

30

DETAILED DESCRIPTION OF THE PREFERRED EMBODIMENT

- 3 -

In the preferred embodiment shown in Figure 1, a fluid 4 is drawn through a venturi 3 by means of a prandtl layer pump 17. The prandtl layer pump 17 consists of a series of flat plates 5 which are connected to a shaft 8 which is in turn connected to a motor 9
5 which provides the motive force to rotate the plates 5. The rotation of the plates 5 causes the fluid 4 to be drawn through the venturi 3 which in turn causes the gas 6 to be drawn from the gas source 1 through tube 2 and into the venturi 3. The gas 6 is drawn into the fluid 4 in such a manner as to form small gas bubbles 7 in the fluid
10 flow stream. The gas laden fluid stream 11 is drawn through openings 10 in the plates 5. A catalyst layer 13 may optionally be applied to the surface of the plates 5 so as to enhance the reaction of constituents of the gas 6 with constituents of the fluid 4.

As the fluid is forced outwards on a radial serpentine
15 path along the rotating plates 5 the pressure of the fluid increases thereby increasing the dissolution of the gas 6 into the liquid 4. This increase in the pressure of the fluid is possible because unlike conventional vane or centrifugal pumps, the prandtl layer pump will not be cavitated by the presence of the gas. The prandtl layer
20 pump may create a force of, for example, up to 100 psig and, more preferably up to 250 psig.

The pressurized gas and liquid mixture 14 may then be passed into an expansion zone 12 wherein the pressure in the gas and liquid mixture 14 is reduced and preferably rapidly reduced. The
25 liquid/gas mixture in the expansion zone may be at a pressure of, for example, 30-60 psig. This depressurization may occur in under 2 seconds, preferably under 1 second and, most preferably, is effectively instantaneous upon the liquid/gas mixture entering expansion zone 12. This depressurization allows the dissolved gas to
30 come out of solution to form a suspension of many ultra-fine (eg. 1 micron to 5 micron) bubbles 15 which effectively reacts with the

- 4 -

constituents of the fluid.

Optionally, a catalyst or catalysts 16 is placed within the expansion zone 12 to enhance the reaction between constituents of the gas and the liquid.

5 In a second embodiment shown in Figure 2, a fluid 4 is drawn through a venturi 3 and a second venturi 20 by means of a prandtl layer pump 17. The prandtl layer pump 17 consists of a series of flat plates 5 which are connected to a shaft 8 which is in turn connected to a motor 9 which provides the motive force to
10 rotate the plates 5. The rotation of the plates 5 causes the fluid 4 to be drawn to venturi 3 and through venturi 20. This in turn causes the gas 6 to be drawn from the gas source 1 through tube 2 and into the venturi 3 and also causes the gas 19 to be drawn from the gas source 22 through the tube means 18 and into the venturi 20. The gases 6
15 and 19 are drawn into the fluid 4 in such a manner to form small gas bubbles 7 and 21 to form in the respective streams of the fluid 4. The gas laden fluid stream 11 formed by the combination of the fluid from venturis 3 and 20, is drawn through openings 10 in the plates 5. A catalyst layer 13 may optionally be applied to the surface
20 of the discs 7 so as to enhance the reaction of constituents of the gases 6 and 19 with each other and/or with constituents of the fluid 4.

As the fluid is forced outwards on a radial serpentine path along the rotating plates 5 the pressure of the fluid increases
25 thereby increasing the dissolution of the gases 6 and 19 into the liquid 4. This increase in the pressure of the fluid is possible because unlike conventional vane or centrifugal pumps, the prandtl layer pump will not be cavitated by the presence of the gas.

30 The pressurized gas and liquid mixture 14 may then be passed into an expansion zone 12 wherein the pressure in the mixtures of gases and liquid 14 is reduced and preferably rapidly

- 5 -

reduced. This depressurization allows the dissolved gases to come out of solution to form a suspension of many ultra-fine (eg. 1 micron to 5 micron) bubbles 15 which effectively reacts the gases which each other and/or with the constituents of the fluid.

5 Optionally, a catalyst or catalysts 16 is placed with the expansion zone 12 to enhance the reaction between constituents of the gas and the liquid.

- 6 -

WE CLAIM

1. An apparatus comprising a prandtl layer pump, an inlet port for introducing at least one gas and at least one liquid to the prandtl layer pump and an outlet port for removing the resultant liquid/gas mixture from the prandtl layer pump.
5
2. The apparatus as claimed in claim 1 further comprising a depressurization zone downstream from the prandtl layer pump.
3. The apparatus as claimed in claim 2 wherein the gas/liquid mixture is rapidly depressurized as it enters the depressurization zone.
10
4. The apparatus as claimed in claim 1 wherein the prandtl layer pump comprises a plurality of discs and a catalyst is applied to at least a portion of one of the discs.
- 15 5. The apparatus as claimed in any of the forgoing claims wherein a catalyst is provided in the depressurization zone.
6. An apparatus comprising a prandtl layer pump, an inlet port for introducing at least two gases and at least one liquid into the prandtl layer pump and an outlet port for removing a mixture of the liquid and the gases wherein the liquid is not reactive with the gases.
20
7. The apparatus as claimed in claim 6 further comprising a depressurization zone downstream from the prandtl layer pump.
8. The apparatus as claimed in claim 7 wherein the gas/liquid mixture is rapidly depressurized as it enters the depressurization zone.
25
9. The apparatus as claimed in claim 6 wherein the prandtl layer pump comprises a plurality of discs and a catalyst is applied to at least a portion of one of the discs.
- 30 10. The apparatus as claimed in claim 4 or 9 wherein a catalyst is in the form of a fluid.

- 7 -

11. The apparatus as claimed in any of the forgoing claims wherein the inlet port comprises at least two venturi, at least one gas being introduced through one of the venturi into the prandtl layer pump and the liquid being introduced through the other venturi into the prandtl layer pump.
- 5 12. A process for compressing a liquid and a gas comprising introducing at least one gas and at least one liquid into a prandtl layer pump and passing the gas and the liquid through the prandtl layer pump to obtain a liquid/gas mixture.
- 10 13. The method as claimed in claim 12 further comprising the step of passing the liquid/gas mixture through a depressurization zone to obtain a liquid/gas mixture at a reduced pressure.
- 15 14. The method as claimed in claim 13 wherein the liquid/gas mixture is rapidly depressurized.

ABSTRACT OF THE DISCLOSURE

A process for compressing a liquid and a gas comprises
introducing at least one gas and at least one liquid into a prandtl
5 layer pump and passing the gas and the liquid through the prandtl
layer pump to obtain a liquid/gas mixture.

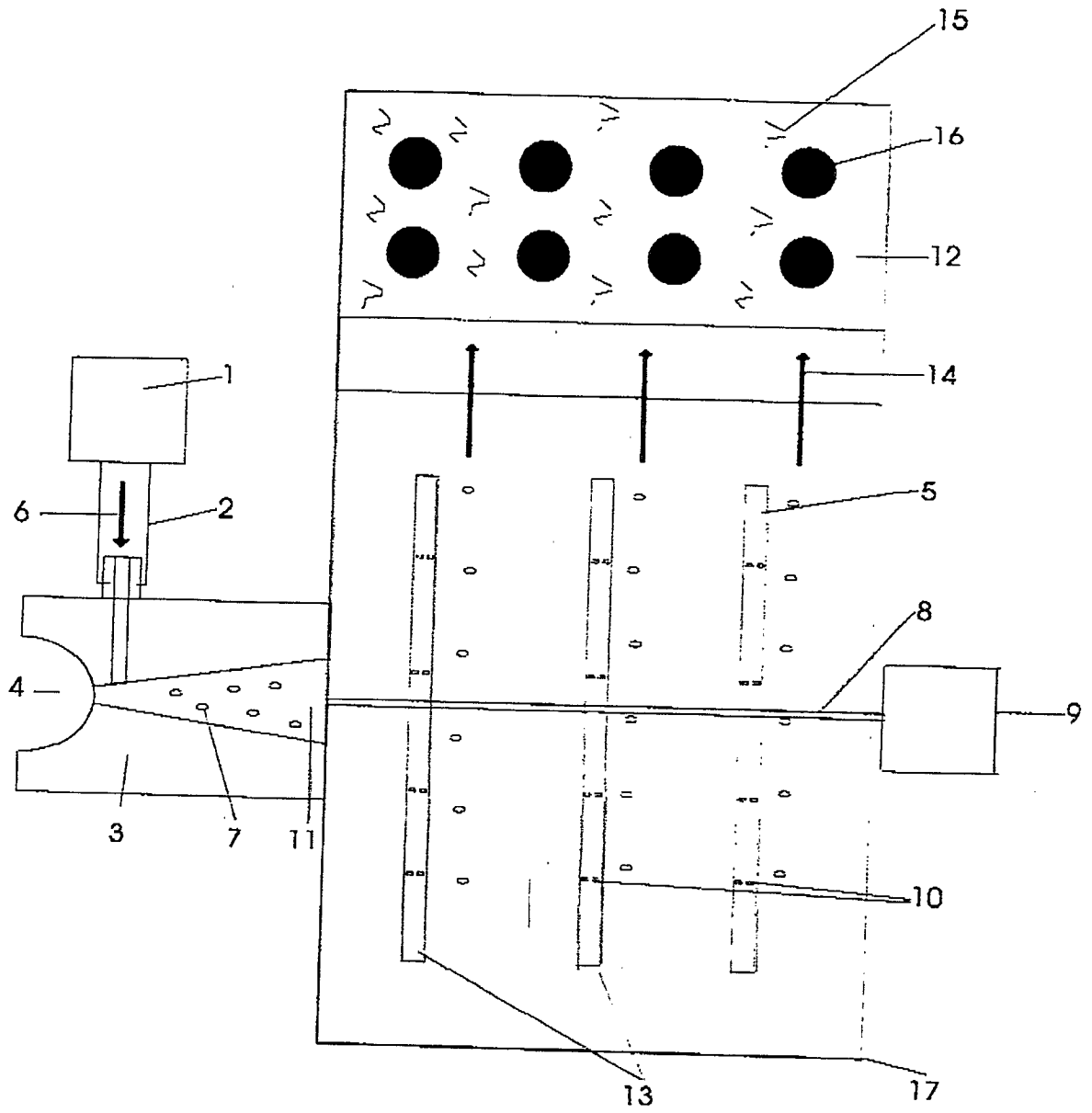

Figure 1

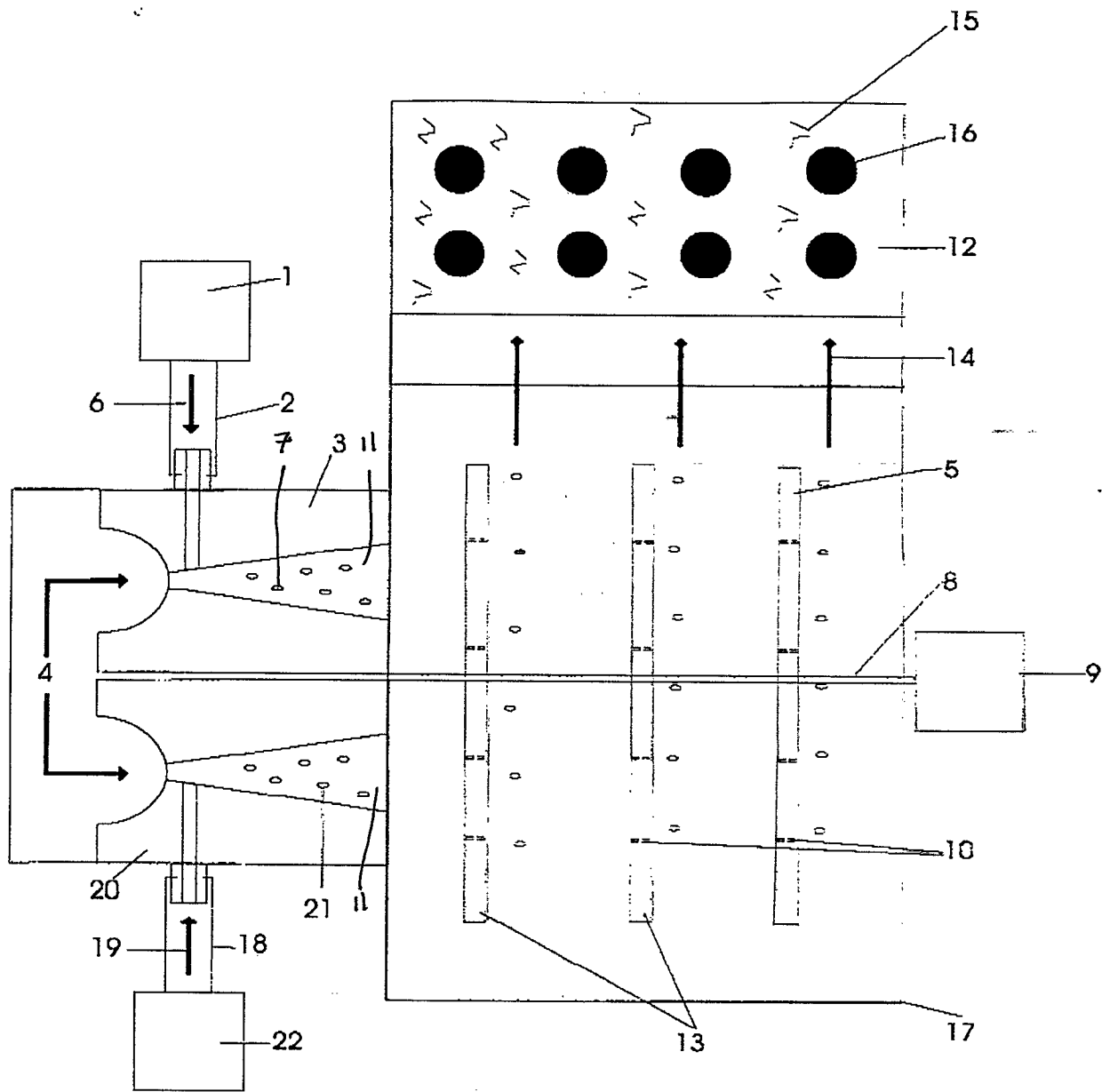

Figure 2